



efi REGGIANI VOGUE

Digital Printer

for Direct Printing on Fabric

In
VOGUE

VOGUE: Mastering speed and printing quality

What you need is what's in VOGUE

VOGUE is EFI™ Reggiani's revolutionary cutting-edge textile printer. Its most fashionable qualities? Mastering speed and tension to ensure the most accurate fabric handling you've ever experienced. Plus, VOGUE's innovative ink recirculation system saves large quantities of ink and reduces maintenance during machine operation and between stoppages.

What's more, VOGUE reduces the need for environmental conditioning, saving energy.

At a glance

New EFI Reggiani printing software

- Real-time image processing converts images without additional calculation
- Allows ink calculation and speed prediction before printing
- Automatically detects width of substrate, allowing image auto centering and set margins

Head electronic

- Now embedded in a fully enclosed protection cap with single cable
- Easier printhead removal and simplified print carriage layout
- Quick and tool free head alignment

Integrated environmental sensor

- Monitors temperature and humidity in the printing chamber with on-screen reporting
- Warns the operator when values are exceeding the set point

EFI Reggiani printing server

- Equipped with RAID 5 high-speed disks, providing high data transfer and redundancy
- Incorporated UPS for data security

New enhanced ink recirculation system, leading to 95% of ink saving

Integrated water filtration system

APPLICATIONS	
Apparel and accessories	✓
Home textile	✓
Sportswear and footwear	✓

INKS	
Reactive	✓
Acid	✓
Disperse direct	✓
Disperse sublimation/Direct	✓
Textile pigment	✓

SUBSTRATES	
Cotton	✓
Polyester	✓
Polyamide	✓
Silk	✓
Viscose	✓
Polyester and elastane	✓
Polyamide and elastane	✓
Blends	✓



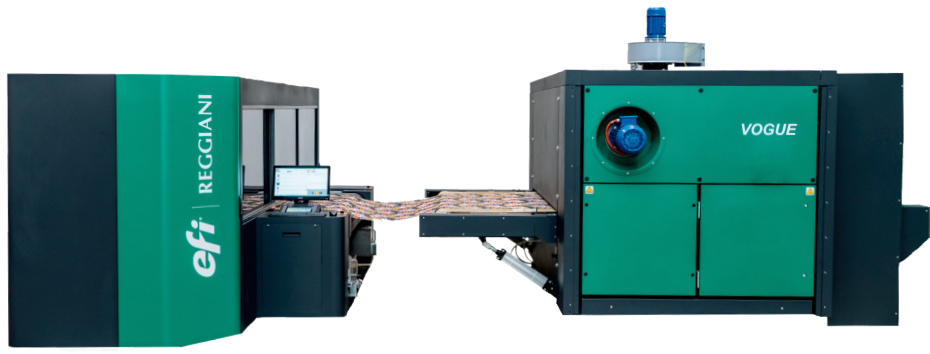

Features

- High-precision transportation belt
- Full variable drop size
- Head crash protective system
- Ink management: in-line continuous degassing and filtering
- Ink supply system with feeding by tanks max 12 lt
- Self-cleaning
- Adhesion method: thermoplastic, permanent, resin
- Embedded magnetic system for adhesive application
- Steel beam with linear motor and magnetic encoder
- Carriage running on stainless steel linear guides
- Stainless steel head plate with recessed nozzle protection
- Ink system open to certified suppliers
- Possibility to monitor and export all printing and machine data to an external DB or ERP
- Software open to main RIP vendors

Advantages

- Smaller footprint on a single block
- Easy and cost efficient maintenance
- Easy access to main machine modules
- Suitable for 24/7 operation
- One operator can manage multiple machines

Improvements

- Higher uniformity printing modes with smoothing feature
- Innovative and adaptive GUI with advanced queuing features

Fiery proServer optimised for EFI Reggiani printers (optional)



 8 COLORS
 16 HEADS
 8 EACH ROW

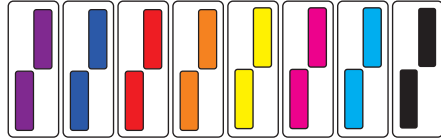

* Further color configurations available

VOGUE			
RESOLUTION	PASS	FT/H	SQFT/H
600x600	2	705	3,500
600x900	3	476	2,370
600x1200	4	345	1,720



Specifications

- **Production speed**
 - Up to 3,500 sqft/h max (325 sqm/h max)
 - Typical printing speed 656 ft/h (200 m/h)
 - Printing heads 16
 - Printing width up to 71 in (180 cm)
 - Drop size from four to 72 pl
 - DPI up to 2400
 - Fabric weight from 1.06 to 12.35 oz/sqft (30 to 350 gr/sqm) (woven and knitted)
- **Fabric feed (Entry)**
 - Roll unwinder up to \varnothing 16 in (400 mm)
- **Fabric take-up (Exit)**
 - Fold
 - Roll winder up to \varnothing 16 in (400 mm)
 - Fold and roll winder up to \varnothing 16 in (400 mm) (optional)
- **Dryer**
 - One industrial chamber with conveyor belt with one or three passages

EFI Reggiani VOGUE: regulatory model ReNOIR 180

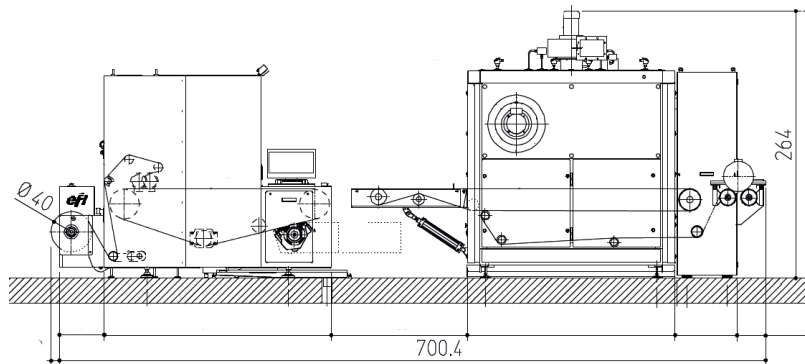

Download the EFI™ Go app and manage VOGUE in real time.



EFI fuels success.

We develop breakthrough technologies for the manufacturing of signage, packaging, textiles, ceramic tiles, and personalized documents, with a wide range of printers, inks, digital front ends, and a comprehensive business and production workflow suite that transforms and streamlines the entire production process, increasing your competitiveness and boosting productivity. Visit www.efi.com or call 650-357-3500 for more information.



Nothing herein should be construed as a warranty in addition to the express warranty statement provided with EFI products and services.

The APPS logo, AutoCal, Auto-Count, Balance, BESTColor, BioVu, BioWare, ColorPASS, Colorproof, ColorWise, Command WorkStation, CopyNet, Cretachrom, Cretaprint, the Cretaprint logo, Cretaprinter, Cretaroller, Digital StoreFront, DocBuilder, DocBuilder Pro, DockNet, DocStream, DSFdesign Studio, Dynamic Wedge, EDOX, EFI, the EFI logo, Electronics For Imaging, Entrac, EPCount, EPhoto, ERegister, EPStatus, Estimate, ExpressPay, FabriVU, Fast-4, Fiery, the Fiery logo, Fiery Driven, the Fiery Driven logo, Fiery JobFlow, Fiery JobMaster, Fiery Link, Fiery Navigator, Fiery Prints, the Fiery Prints logo, Fiery Spark, FreeForm, Hagen, InkIntensity, Inkware, LapNet, Logic, Metrix, MicroPress, MiniNet, Monarch, OneFlow, Pace, Pecas, Pecas Vision, PhotoXposure, PressVu, Printcafe, PrinterSite, PrintFlow, PrintMe, the PrintMe logo, PrintSmith, PrintSmith Site, PrintStream, Print to Win, Prograph, PSI, PSI Flexo, Radius, Remoteproof, RIPChips, RIP-While-Print, Screenproof, SendMe, Sincolor, Splash, Spot-On, TrackNet, UltraPress, UltraTex, UltraVu, UV Series 50, VisualCal, VUTEk, the VUTEk logo, and WebTools are trademarks of Electronics For Imaging, Inc. and/or its wholly owned subsidiaries in the U.S. and/or certain other countries.

All other terms and product names may be trademarks or registered trademarks of their respective owners, and are hereby acknowledged.

© 2018 ELECTRONICS FOR IMAGING, INC. ALL RIGHTS RESERVED. | WWW.EFI.COM

GVP.005.01.18_US